

# PRISM® Nitrogen HN Generators



“Our design brief was to make a plant that could be adapted to meet the needs of individual customers in widely differing markets. As a result, it has proven to be a benchmark in areas as different as Oil Refining and Electronics.”

*Tony Wagstaff  
Business Manager,  
Global Sale of  
Equipment Group*



*Air Products has designed, engineered, manufactured and operated on-site gas generation systems for over 40 years, which has created an outstanding global product line.*

These plants have served a wide variety of industries, including Electronics, Oil and Gas Processing, Petrochemical, Metallurgy, Glass, Pharmaceutical, Food Processing, Power Generation and many others in countries throughout the world.

Air Products' new **PRISM®** Nitrogen HN systems are the latest in a series of developments for this product line. Like all Air Products systems, they are designed to maximise safety, reliability and efficiency. They use proprietary Cryogenic Air Separation Technology and are supplied as a set of pre-fabricated modules which are simple and economic to build, operate and maintain. The plants produce primarily Gaseous Nitrogen, but variable amounts of Liquid Nitrogen can also be produced, stored and then vaporised as required for peak shaving or back-up. In designing the plants, we covered a comprehensive range of flows, pressures and purities to

meet all of the needs of the many industries that we serve.

These plants also provide flexibility through a series of basic design options, which enable us to optimise each plant to suite the individual Client's requirements.

For the Electronics industry, the emphasis is on purity – typically ppb levels of Oxygen in Nitrogen – coupled with high efficiency, low noise, compact layout and short delivery and installation times.

For the Oil, Gas and Petrochemical industries, greater emphasis is often placed on flexibility in production of both Gaseous and Liquid Nitrogen, on reliability, and on our ability to build a plant which complies with project-specific specifications.

All of these requirements can be met with the Air Products **PRISM®** Nitrogen HN system.

## Features and Benefits

- |                           |  |
|---------------------------|--|
| <b>Low Capital Cost</b>   | <ul style="list-style-type: none"> <li>• Standard, pre-engineered plant range</li> <li>• Single distillation column with Air Products proprietary structured packing</li> <li>• Highly skidded for low installation cost</li> </ul>  |
| <b>High Reliability</b>   | <ul style="list-style-type: none"> <li>• Single, integrally geared turbo air compressor</li> <li>• Oil bearing expander</li> <li>• Produces liquid nitrogen for back-up and peak shaving, no trucked in back-up required</li> <li>• Integrated instrument air systems</li> </ul>           |
| <b>Low operating cost</b> | <ul style="list-style-type: none"> <li>• Low pressure option with product compression gives low power consumption</li> <li>• Fully automatic controls for unmanned operation resulting in low manning costs</li> <li>• Optimise by selection of PSA or TSA pre-treatment system</li> </ul> |
| <b>Flexibility</b>        | <ul style="list-style-type: none"> <li>• Variable liquid production to suit fluctuating demand</li> <li>• Other design and operating options – see below for details</li> </ul>  |

## Options Available

Air Products offers a number of options to the plants, including:

- High efficiency operation using low pressure plant operation with PSA pre-treatment system
- High liquid production with high pressure operation and TSA pre-treatment system (with optional chiller)
- Ultra-high liquid production (typically 50% of total production) with special design
- Ultra-high purity to 1 ppb O<sub>2</sub> for electronics wafer fabs and CDA (Clean Dry Air)
- Closed loop cooling water, open tower cooling water or air cooled options
- Control by Integrated PLC (Programmable Logic Controller), or directly by Client DCS
- Air supply by integrated compressor with typical turndown to approximately 75% of maximum
- Air supply from Client's air main, with typical turndown to approximately 50% of maximum, or better.
- Higher pressure supplied by product compression.
- Installation and start-up by Air Products or FOB supply only

## Process Description

Atmospheric air is compressed in the main air compressor (MAC) and cooled in the compressor aftercooler. The air then passes through a 2-bed adsorption system to remove water vapour, carbon dioxide and heavier hydrocarbons. The two adsorber beds operate alternatively, one being regenerated whilst the other is in service. Regeneration is achieved by passing dry, waste gas from the plant through the adsorber. The adsorber switching sequence and plant operation is controlled either by an Air Products supplied programmable logic controller (PLC), or, if preferred, by the Client distributed control system (DCS).

Dry air from the adsorbers enters the cold box. It is cooled and partially liquefied by heat exchange with the returning product and waste streams in the main exchanger. The cold, partially liquefied air and gas mixture, passes into the bottom of the distillation column where the ascending vapour is separated into pure nitrogen at the top of the column and crude liquid oxygen at the base of the column. The high purity nitrogen leaves the top of the column and passes to the reboiler/condenser where it is condensed and either returned to

the HP column as reflux or sent to storage as liquid product. The crude liquid oxygen from the sump of the distillation column is flashed into the reboiler section to provide refrigeration for condensing the gaseous nitrogen. A continuous purge of oxygen enriched liquid is removed from the reboiler sump to prevent the build-up of hydrocarbons and CO<sub>2</sub>. Refrigeration for the overall process is provided when part of the waste gas leaving the reboiler/condenser is warmed in the main heat exchanger and the total mixed stream is expanded to near atmospheric pressure in the expander with a corresponding drop in temperature. Passing this cold waste gas back through the main heat exchanger cools the incoming air and a side stream of the waste gas leaving the heat exchanger is used to regenerate the adsorbers. Pure gaseous nitrogen from the top of the HP column is heated to near ambient temperatures in the main heat exchanger before leaving the cold box. It then combines with any make-up from the storage vaporisers before leaving the plant.

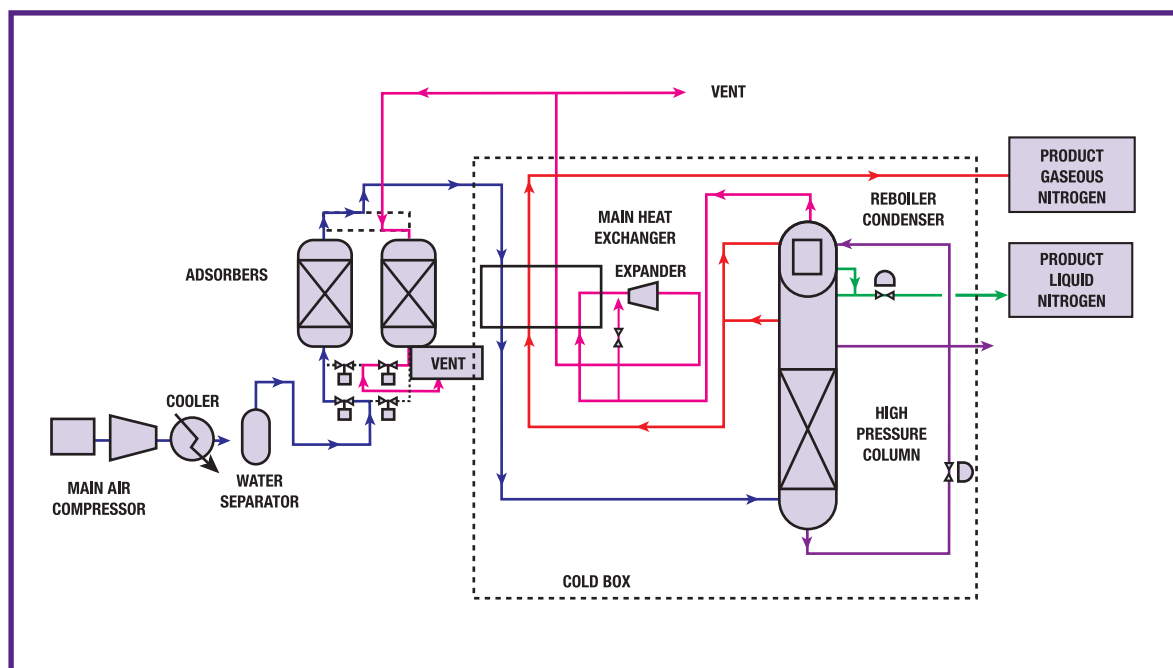

## PRISM® HN Performance

The **PRISM®** Nitrogen HN system plant range covers the full range of gaseous nitrogen duties up to 10,000 Nm<sup>3</sup>/h, with simultaneous liquid nitrogen production of up to 2,000 Nm<sup>3</sup>/h. The performance map opposite outlines the general performance capability of the various plants in the range. Note that unit performance can be affected by varying ambient conditions, and also by the operating pressure that is selected during the plant design process.

### Conversion Factor:

1 Metric Ton Per Day = 33.34 Nm<sup>3</sup>/h = 1268 scfh

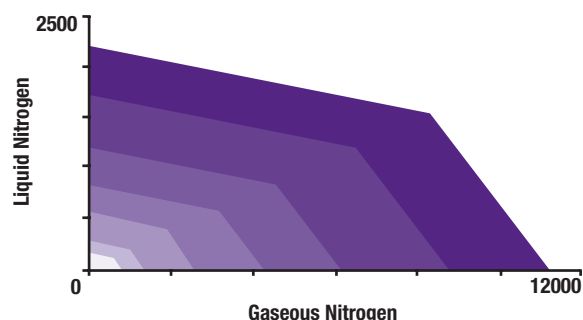

## Typical Plot Layout and Block Flow Diagram

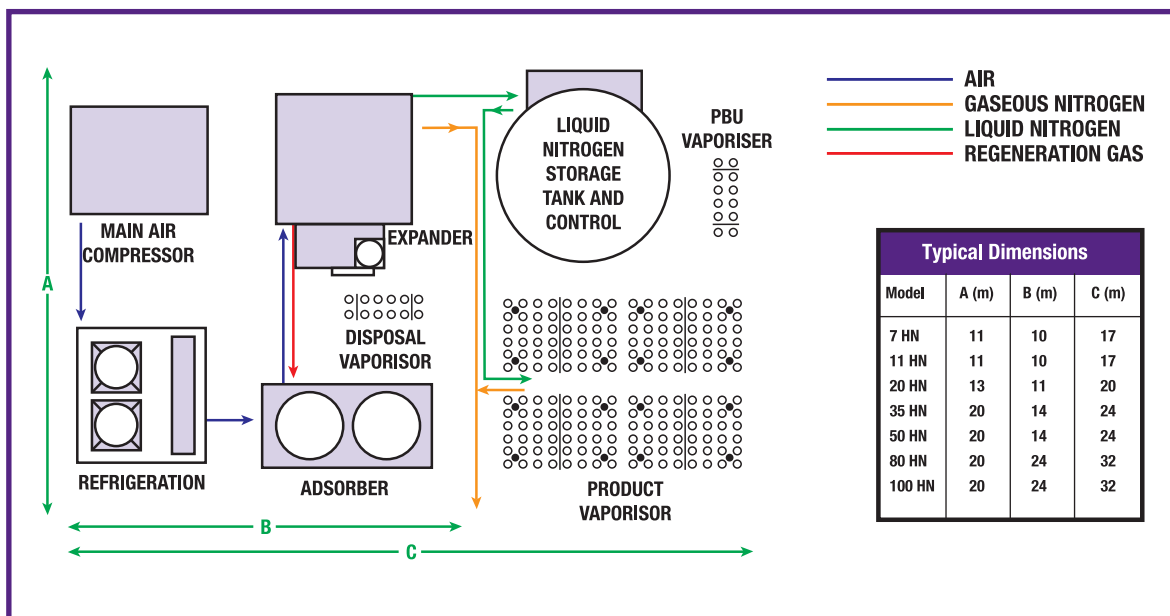

## Standards and Specifications

### Safety, Health & Environment

Air Products believes that nothing is more important than safety.

We have extensive Safety Management systems, procedures (including HAZOP analysis) and detailed engineering standards, as well as 50 years of Air Separation plant operation experience. This expertise is applied to all plant and equipment that Air Products operates and sells, to ensure the safety of employees, customers and the general community. As a result Air Products is widely acknowledged to be the safety leader in the industrial gas industry and also has one of the leading performances in the chemical industry as a whole.

### Quality

Air Products PLC engineering and manufacturing operates under QA procedures, certified under ISO9001 since 1983.

### Pressure vessels

These are normally manufactured to ASME VIII (with U-stamp) or to European PED, but other codes can be accommodated where necessary.

### Piping

ASME B31.3 as standard, DIN where required.

### Electrics

IEC, CE plated as standard, NEMA where required.

### Noise level

85 dB(A) at 1 metre as standard, in a "free field" area with no other noise sources considered. Lower levels can be achieved where required.

### Typical Supply Schedule

Equipment Manufacture												
Site Preparation												
Equipment Installation												
Commissioning & Start-up												
On-Stream												
Months	1	2	3	4	5	6	7	8	9	10	11	12

### Scope of Supply

**Descriptions:**

Air Products *PRISM*® Nitrogen HN plants are designed to be tailored to meet the specific requirements of each Customer. The scope of supply of each plant can also be tailored to best address the interests of the Customer. As well as designing and supplying the equipment, Air Products offers a broad complement of service options. These service options build on the base equipment package to provide a full product supply system, complete with long-term operation, maintenance, and ownership of the equipment. An Air Products Commercial Manager would work directly with the Customer to identify the optimum level of service options.

### Typical Equipment Supply

- Air Compression System
- Air Pre-Treatment System
- Cold Box including Distillation Column
- Cryogenic Expander
- Instrumentation and Controls
- Interconnecting Piping
- Product Compression (optional)
- Liquid Storage & Vaporization (optional)
- Preparation for Shipment
- Delivery to Agreed Point
- Engineering and Procurement Services
- Project Management

### Available Service Options

- License and Permit Assistance
- Foundation Design and Construction
- Complete Installation Package
- Equipment Delivery to Site
- Full Equipment Installation
- Utilities Design and Supply
- Startup and Commissioning of System
- Plant Operation and Safety Training
- Ongoing Operation and Maintenance
- Liquid Supply for Backup & Peakshaving
- Product Pipe Line to Point of Use
- Application Testing & Optimisation

### How to contact Air Products:

**Europe**

Air Products PLC  
 Hersham Place  
 Molesey Road  
 Walton-on-Thames  
 Surrey KT12 4RZ  
**Tel: +44 (0) 800 389 0202**  
**Fax: +44 (0) 1932 258502**

**USA**

Air Products and Chemicals, Inc.  
 7201 Hamilton Boulevard  
 Allentown  
 PA 18195-1501  
**Tel: 800 654 4567**  
**Int'l: +1 610 706 4730**  
**Fax: 800 880 5204**

**Asia**

Air Products Asia, Inc.  
 9 Temasek  
 #28-01 Suntec Tower 2  
 Singapore 038989  
**Tel: +65 (0) 332 1610**  
**Fax: +65 (0) 332 1600**

email: [info@apci.com](mailto:info@apci.com)

**tell me more**

[www.airproducts.com/prism](http://www.airproducts.com/prism)

*PRISM*® is a registered trademark of Air Products and Chemicals, Inc.